

Replacement Parts



List EmberGlo® Steamer Model ES5TS

*Tap Water Operation
Designed to Operate
Without Distilled Water*



Automatic Timer/Push Button Operation
Steamer with Water Pan

Installation and Service Manual - 8449-96

Date Code - Model ES5TS first construction August 1985

Items listed are replacement parts for the current Model ES5TS Tap Water Steamer and its components.

- EmberGlo Steamers do not require a separate hood for vapor produced during operation according to the Uniform Mechanical Codes per the International Conference of Building Officials Code.



EmberGlo®

EmberGlo
A Div of Midco® International Inc.
4140 West Victoria Street
Chicago, Illinois 60646
toll free 866.705.0514
tel 773.604.8700
fax 773.604.4070
web www.emberglo.com
e-mail sales@emberglo.com

AVOID ERROR IN PARTS SELECTION. When ordering use complete EmberGlo Part Number and Description. Furnish Model Number, Bill of Material Number and Serial Number (if available) from the specification plate found on the product.

IMPORTANT: Availability of parts as well as specifications are subject to change without notice.

Quality Designed for Proven Performance

411
8472 51
Printed in USA

ES5TS Exploded View

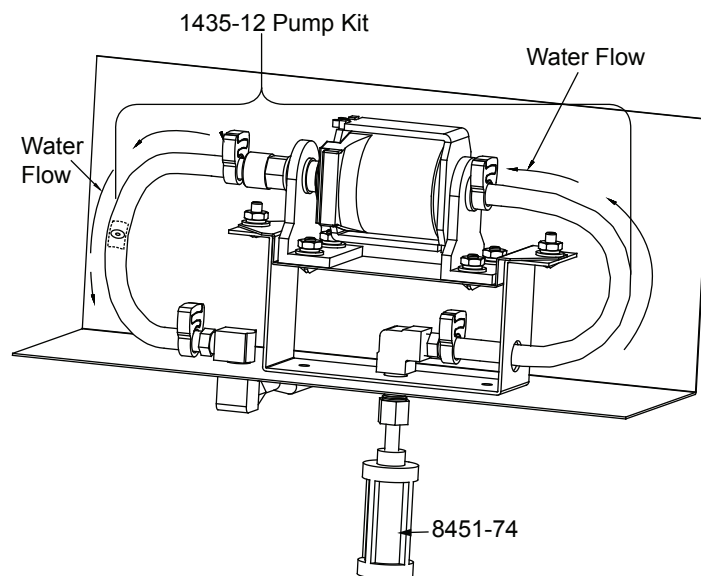
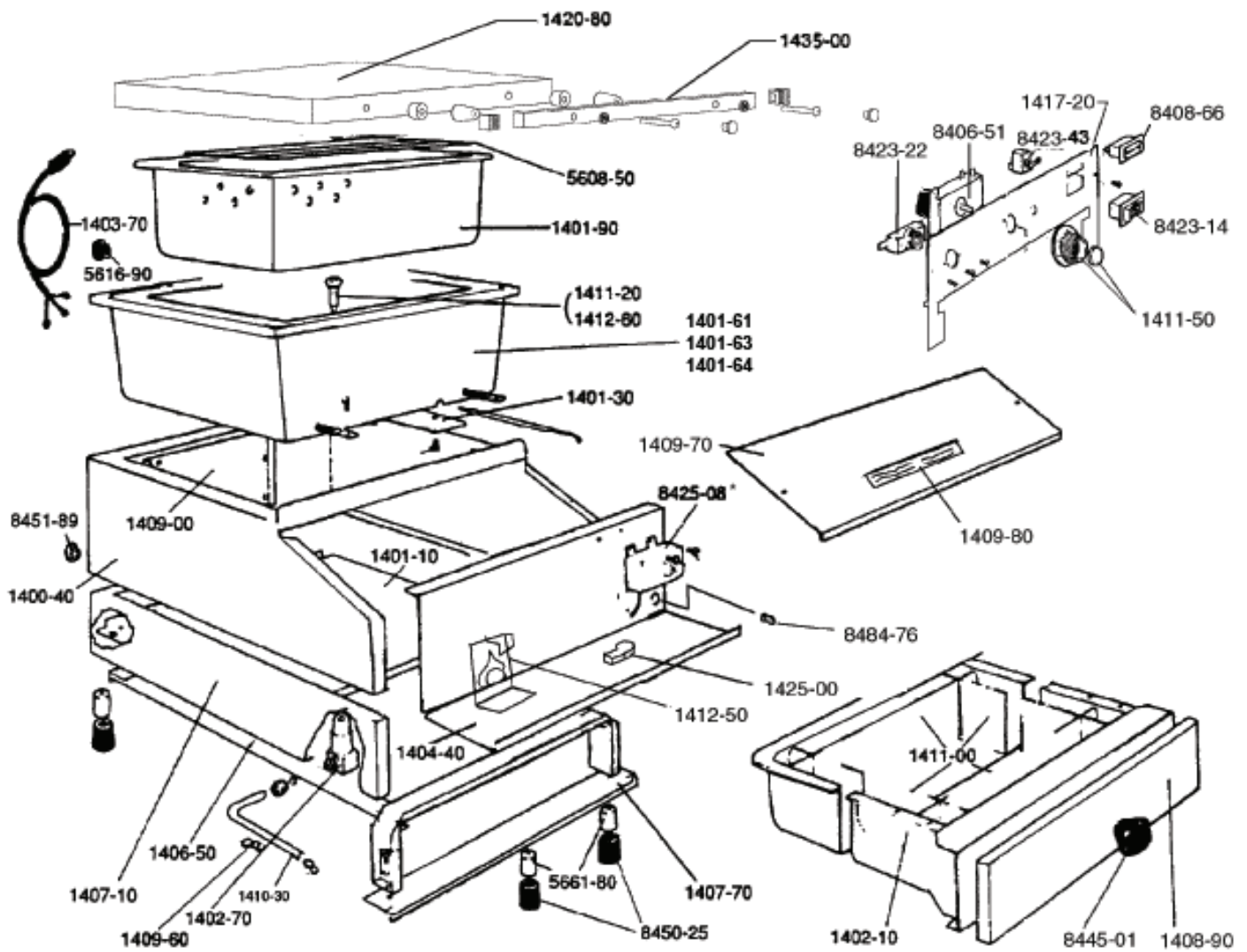

ES5TS Parts List

Part #	Description	Qty	Part #	Description	Qty
1400-40	Shell Weldment	1	8406-51	Main Timer (120 volt, 30 min.) Timer & Button	1
1401-10	Rear Bottom	1	8408-66	Ready Light	1
1401-30	Bulb Clamp	1	8423-15	On-Off Rocker Switch	1
1401-64	Generator (120 volt)	1	8423-22	Push Button Switch	1
1401-61	Generator (220 volt)	1	8423-43	Toggle Switch (Buzzer Switch)	1
1401-63	Generator (1800 Watt)	1	8425-08	Thermostat	1
1401-90	Food Pan	1	8445-01	Water Pan Knob	1
1402-10	Water Pan Rivetment	1	8450-25	Socket Tip (4 required)	4
1402-70	Water Inlet	1	8451-74	Water Filter Strainer	1
1403-70	Power Cord (3 Prong, 120 volt)	1	8484-76	Snap Bushing (B-500-375)	1
1406-50	Water Pan Slide Weldment	1			
1407-10	Water Pan Shell Weldment	1			
1407-70	Leg Channel	1			
1408-90	Water Pan Front	1			
1409-60	Water Tube Clip (2 required)	2			
1409-70	Control Box Cover Assembly	1			
1409-80	Timer Label	1			
1410-30	Short Water Tube and Fittings	1			
1411-00	Water Pan Baffle Set	1			
1411-20	Water Nozzle with Spring	1			
1411-50	Timer Dial and Button (30 min.)	1			
1412-50	Shot Timer Assembly (120 volt)	1			
1417-00	Pump Bracket	1			
1417-20	Switch Panel	1			
1417-40	Front Bottom Panel	1			
1420-80	Lid and Handle Assembly	1			
1425-00	Buzzer Assembly	1			
1435-00	Lid Handle Replacement Kit	1			
1435-12	Pump Repl Kit	1			
5608-50	Food Grid	1			
5661-80	Aluminum Leg (4 required)	4			
5616-90	Strain Relief (SR-6P-4)	1			

Not Shown

1410-50	Insulation Kit (Sides, Back, Front & Bottom)	1
1411-70	Electrical Wire Kit (less power cord)	1
1412-41	Thermal Fuse Kit with Instructions	1
1420-00	Spring bar	2
1421-45	Back Hinge Kit (less spring bar & spring)	1
1416-00	Dip Tube Assembly	1
1416-60	Pump Orifice	1
5622-00	EmberGlo Name Plate	1

Accessories - Not Shown

5608-71	TorPita -Tortilla/Pita Rack w/ Handle
5608-53	Mesh Food Pan Grid w/ Separator
5608-70	Three in 1 Basket Kit w/ Handle
5608-72	1/2 Size Basket w/ Handle
5608-73	Two of 1/4 Size Basket w/ Handle
5608-61	Egg Poacher 6 Cup
8450-62	Steam Generator Cleaning Brush

ADJUSTABLE HINGE FOR 2-POSITION LID OPENING (60° OR 90° OPEN)

First construction January 29, 1990 (date code 0590). Steamers built before this date featured a 90° opening lid. Replacement parts for the early construction are no longer available. When replacing order Part Number 1421-45 ADJUSTABLE HINGE RETROFIT KIT.

Part # or Item #	Description	Qty
1	Adjustable Upper Hinge	1
2	Lid Stop Rivetment	1
3	Upper Hinge Bar	1
4	Adjustable Lower Hinge	1
5	5/16" x 3/16" O-Ring	2
Not Shown - (Sold Separately)		
1420-00	Spring bar	2
1420-40	ES5 Hinge Spring	2

