

# Installation and Service Instructions



Model ES5PB

## ES5 Series Top Open / Half Pan Counter Top Steamer

- ES5TS:** Timer Operation with Water Pan
- ES5M:** Manual Operation with Water Pan
- ES5PBS:** Manual Operation with Push Button and Water Pan
- ES5PB:** Direct Connect with Push Button
- ES5T:** Direct Connect with Timer
- ES5PTS:** Fixed Timer Operation with Water Pan with Push Button

ES5Series - Designed to operate without distilled water, Self Contained or Direct Water Hookup, Stainless steel construction

### Specifications:

- 120 volts 60HZ AC 1500 watts, max 12.5 amp
- ES5 1800 series - 1800 watts, max 15 amps
- Manual pump (push button) or timer operation
- Closed generator
- Half Pan size
- Removable water drawer (self contained models)
- Spring loaded adjustable hinge with 60° or 90° opening
- Food Grid
- ES5 1800 series - 1800 watts, max 15 amps
- ES5 1800 series - 20% faster temperature recovery time
- Quick connect fittings (direct hookup models)

### Warranty

See the back of this manual for warranty.

This warranty does not apply to damages resulting from accident, misuse, abuse or alteration.

No equipment may be returned without written authorization from EmberGlo (or Midco). Returned goods must be shipped prepaid to the factory.

Warranty card must be filled in and returned to EmberGlo (or Midco) to validate warranty.

This manual contains sufficient information for installation of the EmberGlo Steamer in normal locations.

In the United States, installation must conform with local codes.

**PURCHASER: Retain these instructions for future use.** Post in a prominent location near the steamer.

**CAUTION:** Cooking equipment should be used in an environment protected by an automatic fire suppression system. Consult the National Fire Protection Association NFPA Code 96 or the latest edition of Standards for Installation of Equipment for Removal of Smoke and Grease-Laden Vapors From Commercial Cooking Equipment.

**WARNING:** Improper installation, adjustment, alteration, service or maintenance can cause property damage, injury or death. Read the installation, operating and maintenance instructions thoroughly before installing or servicing this equipment.

**AVOID ERROR IN PARTS SELECTION.** When ordering use complete EMBERGLO Part Number and Description. Furnish Model Number, Bill of Material Number and Serial Number (if available) from the specification plate found on the product. **IMPORTANT:** Availability of parts as well as specifications are subject to change without notice. Please consult factory for item availability.

**SAFETY INFORMATION TERMS:** The following terms are used to identify hazards, safety precaution of special notations and have standard meanings throughout this manual. They are printed in all capital letters using a bold type face as shown below, and preceded by the exclamation mark symbol. When you see the safety alert symbol and one of the safety information terms as shown below, be aware of the hazard potential.



- DANGER:** Identifies the most serious hazards which will result in severe personal injury or death.
- WARNING:** Signifies a hazard that could result in personal injury or death.
- CAUTION:** Identifies unsafe practices which would result in minor personal injury or product and property damage.



**EmberGlo**

EmberGlo  
A Div of Midco® International Inc.  
4140 West Victoria Street  
Chicago, Illinois 60646  
toll free 866.705.0514  
tel 773.604.8700  
fax 773.604.4070  
web www.emberglo.com  
e-mail sales@emberglo.com

Quality Designed for Proven Performance



511  
8449 96  
Printed in USA

# ES5 Series - Installation

## Installation

In the United States, wiring must conform to local codes, or in the absence of local codes, to the **National Electrical code ANSI/NFPA No. 70**-latest edition. In **Canada**, wiring must conform to local codes, or in the absence of local codes, to **Canadian Electrical Code Part 1, CSA Standard C22.1**.

1. **All ES5 Models:** Locate on level surface and plug power cord into 120 volt, single phase 60 Hz. grounded outlet.
2. **ES5M, ES5TS, ES5PTS & ES5PBS:** Fill water pan by pulling water pan out to stop position and fill with cold water to top of baffles, then close drawer.
3. **ES5PB & ES5T:** Connect water hose assembly to water supply system. The supply end has 1/8" female pipe fitting and should be attached down stream to a shut-off valve. Steamer end of hose has a quick connect fitting which snaps onto mating fitting on steamer. This fitting has an automatic shut-off valve that allows steamer to be disconnected without shutting off water supply. After connecting, turn on water and check for leaks.
4. EmberGlo Steamers do not require a separate hood for vapor produced during operation according to the Uniform Mechanical Codes per the International Conference of Building Officials Code. And there are **no requirements in NSF Standard 4 (2006e) for steamers to have ventilation**.

## Operation

**General Instructions for Operation.** For operation tips and recommendations see below.

1. Push power switch to ON position (light on) and allow approximately 15-20 minutes to reach operating temperature.
2. Test to make sure unit will generate steam.
3. Open lid, place food on grid and close lid.
4. **ES5M:** Rotate pump handle clockwise until it stops - then release. **See Heating and Cooking Guide - 8474-75S** for suggested number of operations or "shots" (a shot is one rotation of pump handle).  
**ES5PB & ES5PBS:** Push round button momentarily for each operation. Do not hold button more than one second.  
**ES5PTS:** Operates the same as the **ES5PB**, as stated above. Unit will automatically deliver three shots per minute. At the end of cooking time, the ready light will come ON.

**Note:** After installation, operate several times until the water hose fills with water.

**ES5T & ES5TS:** Operate the same as ES5PB above, or follow directions on label on front of unit which will automatically deliver three shots per minute for time set. At end of cooking time, READY light will come ON and signal will sound. Turn toggle switch to OFF to silence signal.

5. Open lid and remove food.
6. For efficiency and safety purposes, keep lid closed when not in use. This keeps the food pan hot and reduces condensation in the steam chamber.
7. To shut off, push power switch to OFF position.

**IMPORTANT: KEEP LID CLOSED WHEN NOT IN USE.** This keeps the food pan hot and reduces condensation in the steam chamber. When steamer is first installed, or when reconnecting water hose, operate STEAM button several times to purge air from lines.

### General Tips and Recommendations for Operation.

To sustain optimum cooking performance: It is important to maintain the correct amount of steam generated. Either holding the manual pump (ES5M) or pressing the button (ES5PB or ES5PBS) too long will flood the generator with too much water. On the other hand not holding the pump (ES5M) or pressing the button (ES5PB & ES5PBS) long enough and not spraying enough water will **not** produce enough steam on the generator to properly cook the food in the desired time.

### Recommended pumping and button pressing times for proper water levels in the generator:

**ES5M** - It is recommended that the user pump the handle two to three times every 20 to 30 seconds. If it is pumped more times or if the user does not wait long enough between pumps, the generator will flood. Also, if it is pumped only once every minute there will not be enough water in the generator to produce the correct amount of steam to sustain optimal cooking performance.

**ES5PB & ES5PBS** - It is important to hold the button in for 3 seconds of time. If the button is held too long, the generator will flood. If the button is held too short of a time, not enough water will be sprayed onto the generator to create enough cooking steam. See below (next paragraph) for recommendations on how to know this.

Recommended Procedure for Understanding the Amount of Steam Generated in both the Manual and Push Button Types of Steamers:

1. On a cool steamer take the food rack and food pan out of the steamer so that the generator And water nozzle can be seen.
2. Warm up the unit for 10 to 15 minutes.
3. ES5M - Push the manual lever two to three times  
ES5PB & ES5PBS - Push the button long enough to spray water on the generator surface.
4. Watch the water turn into steam. All of the water should evaporate in approximately 20 to 30 seconds.

By pumping the manual lever (ES5M) or pushing the button (ES5PB & ES5PBS) and watching the time it takes to evaporate the water, the user will learn how to reach the optimal cooking results, whether by pushing the button in or pumping the manual lever.

Timer Type of Steamers - (ES5TS & ES5T) - this timing is internally set by the manufacture to obtain the optimum cooking steam cycle.

**Food Pan and Grid** on all models should be removed and washed with a detergent or run through a dishwasher.

**⚠ WARNING: Under no circumstances should the entire steamer be run through a dishwasher. If any of the switches or components get wet they can malfunction. Never try to use a device that has been wet— replace it.**

**⚠ WARNING: Perform all maintenance when the unit is cool.**

**Exterior of unit** should be wiped with a damp cloth or cleaned with a stainless steel cleaner.

**Water Pan** on **ES5M, ES5TS, ES5PTS & ES5PBS** may be removed for cleaning by pulling out to stop position; lift front of steamer about 3" to clear pump and pull pan all the way out. To replace, lift front of steamer about 3", slide pan in pan track until it is about 2" from closed position, then lower steamer front and push pan completely in.

**Generator:** The cavity in the generator may accumulate lime and is cleaned by scraping or wire brushing. Do not remove all of this deposit since a thin coating improves steaming.

**Water Nozzle:** The water nozzle, the round cap in front center of generator, may be pulled out for cleaning. Clean small holes and inside of tube with spring clip provided in the tube.

**Water Inlet:** If the tube through generator is limed, remove plug at bottom and push lime out with a wire or small rod.

**Strainers:**

**ES5M:** Strainer is in bottom of pump. Remove wire ring, then strainer wash and replace.

**ES5TS, ES5PTS & ES5PBS:** Strainer is located in front center of bottom. Slip strainer off Tube, wash and replace.

**ES5PB & ES5T:** To wash strainer located in hose:

1. Remove hose.
2. Remove quick connect fitting.
3. Reverse hose (connect steamer end to supply valve). Drain into sink or bucket.
4. Run water through hose to clean.
5. Return to original connections.

There is a strainer in inlet of solenoid valve that normally does not require cleaning but under extreme conditions may have to be removed and cleaned.

**⚠ DANGER: Before attempting service, unplug power cord.**

We recommend any service be done by qualified service personnel. Refer to separate Parts List for parts identification and assembly guide.

1. All electrical components are contained in enclosure behind switch panel. For access, remove sloping front and switch panel.
2. ES5M pump is easily removed for service or replacement. Disconnect water line (under steamer) from pump, open electric enclosure, disconnect linkage and remove two screws holding pump.
3. To remove ES5TS, ES5PTS & ES5PBS pump:
  - A. Disconnect electric wires from terminals.
  - B. Disconnect discharge hose from pump.
  - C. Remove two screws through bottom of steamer holding pump bracket.
  - D. Lift pump out.

*Installation  
Continued*

*Maintenance  
As Required*

*Maintenance  
Daily*

*Service*

# ES5 Series - Wiring Diagrams

Figure 1a

## Wiring Diagrams for ES5 Series Steamers

**ES5M**

**ES5PB**

**ES5PBS**

**ES5T with Mechanical Timer**

**ES5TS with Mechanical Timer**

*\*ES5 1800 Series Steamers have an 1800 watt heating element*

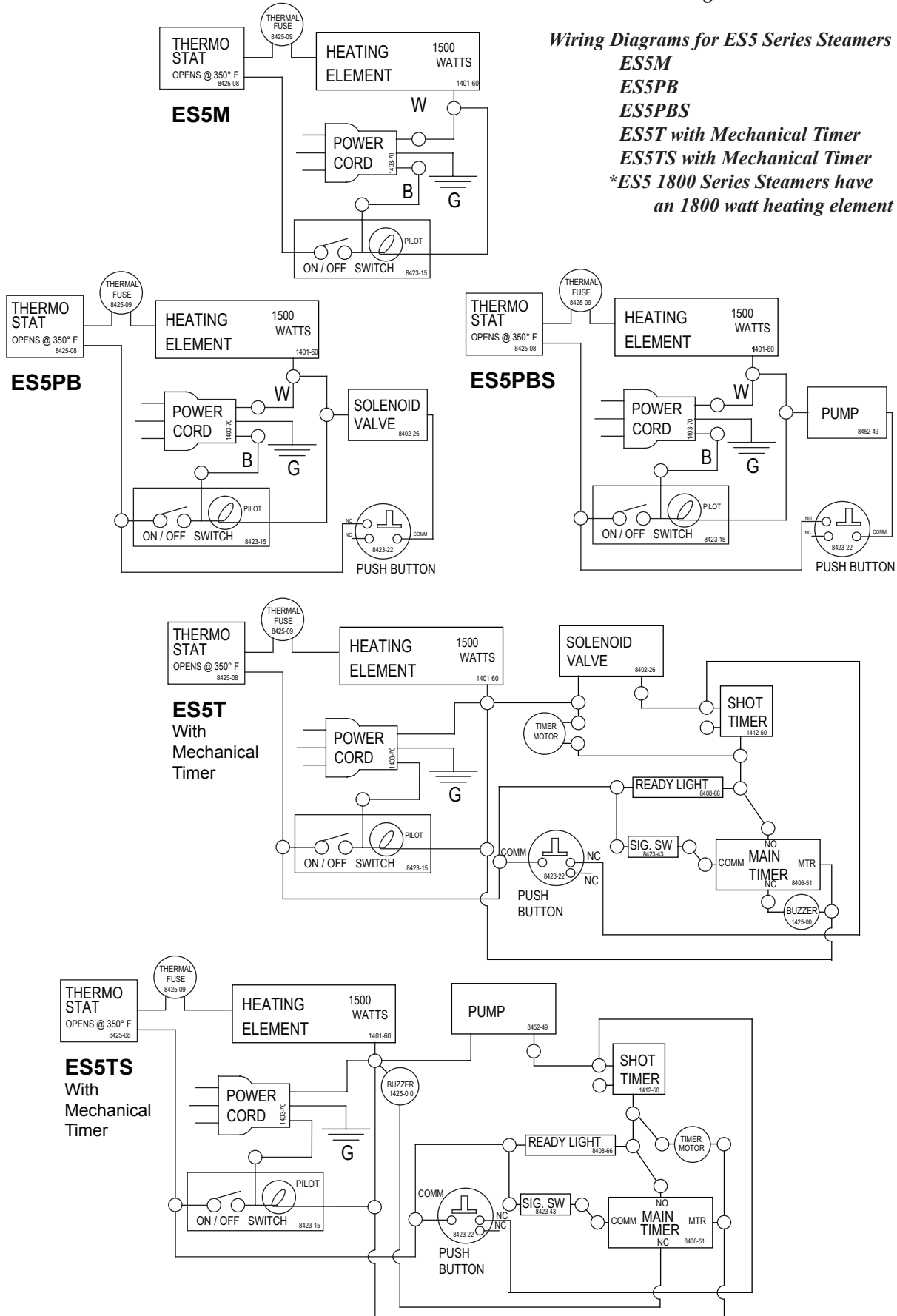

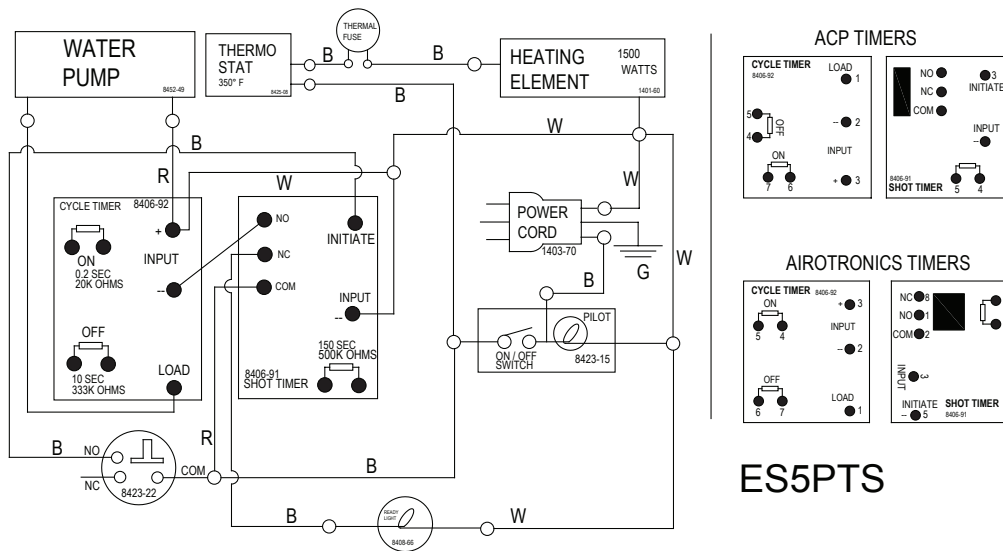

Figure 1b. Wiring Diagrams for ES5 Series Steamers

4. To adjust lid, loosen screws in lower hinge. With lid closed, tighten screws.
5. Thermostat is set to control temperature from 350° to 375°, and we suggest replacement if off calibration. Thermostat may be removed by:
  - A. Removing electric enclosure covers and switch panel.
  - B. Removing wires from thermostat terminals.
  - C. Removing two screws holding thermostat.
  - D. Pull capillary straight out to remove bulb.

**CAUTION:** Capillary tube is critical and care should be taken not to “kink”.

6. If water nozzle should clog with lime, remove by lifting up then clean small holes with paper clip or similar tool. Lime inside tube is removed by flexing tube, then shaking or washing out lime.
7. The water inlet is cleaned by removing plug at bottom and pushing lime out with wire or rod.
8. The main timer controls the cooking time and the shot timer delivers a measured amount of water to produce steam every 20 seconds. If defective, replace (attempted service may affect timing).

**DANGER:** Read and understand this bulletin thoroughly before starting any troubleshooting. An inadvertent service error could result in severe personal injury or death. Only a trained experienced service technician should attempt any repair procedure.

Qualified service agencies are available at most locations—Refer to EmberGlo listing of Authorized Service Agencies included in Standard Equipment Catalog.  
Important: Defective wiring or loose connections can simulate the defects outlined below. Check associated wiring before replacing a component.

*Service  
Continued*

# ES5 Series - Trouble Chart

## Trouble Shooting

### 1. Unit Does Not Heat Switch On, Light Out

- A. Confirm electric cord is securely plugged in.
- B. Confirm receptacle is energized—reset breaker or repair house wiring.

**⚠ WARNING: The following checks thru VII.A.1. should be done with electric cord removed from receptacle.**

- C. Confirm continuity in 3-conductor cord—replace if defective.
- D. Confirm continuity in single pole, single throw Power Switch (the two adjacent terminals are switch terminals and the remote terminal is a tie-terminal). Replace if defective.

### 2. Unit Does Not Heat Switch On, Light On

- A. Confirm continuity of Thermostat—replace if defective.
- B. Confirm continuity of Heating Element—replace Steam Generator Casting if defective.
- C. Confirm Thermal cutoff.

### 3. Unit Heats Switch on, Light Out.

- A. Defective light in switch— replace entire switch.

### 4. Unit Heats Up, But Does Not Steam— No Water Evident on, Light Out.

- A. All Models: Clogged water nozzle, water inlet or strainers—check and clean as required, see Maintenance and Service sections.
- B. Models ES5M, ES5TS, ES5PTS & ES5PBS: Water pan empty—fill pan.
- C. Model ES5M: Confirm pump is operative—check valves—inlet hose must not leak. See Service section. Rebuild or replace as required.
- D. Models ES5PB & ES5T:
  - 1. Confirm Water Shut-Off Valve is on and Water Hose Assembly is properly hooked up. Refer to #3 from the Installation section page 2. A quick way to confirm water line is operational is to disconnect Water Hose at quick disconnect fitting and push a small probe into quick disconnect fitting—water should flow freely.
  - 2. Confirm continuity of Water Solenoid Valve—replace if defective.
- E. Models ES5T, ES5PB, ES5PBS, ES5PTS & ES5TS: Confirm continuity of Steam Push Button Switch when depressed—replace if defective.
- F. Models ES5TS, ES5PTS & ES5PBS:
  - 1. Confirm continuity of Oscillating Pump—replace if defective.
  - 2. Confirm integrity of hoses and fittings. Any and all leakage must be eliminated.

### 5. Unit Floods— Switch On

- A. Models ES5T & ES5PB: Water Solenoid Valve seat dirty—clean or replace as required.

### 6. Unit Works— Ready Light Inoperative

- A. Models ES5T, ES5PTS & ES5TS: Confirm continuity of light—replace if defective.

### 7. Unit Works with Push Button But Not With Timer— Signal Switch On

- A. Models ES5T & ES5TS:
  - 1. Confirm continuity of SPST signal toggle switch—replace if defective.

**⚠ WARNING: The following checks should be done with power to unit. Use extreme care as bare wire terminals and/or bare wires are exposed.**

- 2. Ready Light should go out when Main Timer button is pushed and then if at end of timing, Ready Light goes out and buzzer sounds—replace Shot Timer.
- 3. If Ready Light does not go out when timer button is pushed or if Shot Timer does not run—replace Main Timer.

### 8. Buzzer Does Not Sound at End of Timing— Signal Switch On

- A. Set Main Timer to 0 and Confirm for 120 volts to GND at NC terminal of Main Timer. If none, replace Main Timer.
- B. If 120 volts is present in above test, Buzzer is defective—replace.

These suggestions are made only to help the operator get started. Since each location will have different portions and different requirements, each operator must determine his own operation habits. Please remember that the steamer conserves its steam in the drawer and therefore does not often need repeated shots. The main exception is when frozen product must be defrosted.

**If a product is at room temperature or refrigerated**, start with 2 shots. This ensures that the food pan is full of steam.

**If a product is frozen**, start with 3 shots because condensation on the cold product eliminates the steam quickly.

### BREADS

Croissant.....	
Dinner Rolls.....	
Flour Tortillas.....	
Hamburger Buns.....	
Hard Rolls.....	
Hoagies.....	
Hot Dog Buns.....	
Oat or Bran Muffins.....	
Pastries.....	

### MINUTES

1 Shot 15 Sec.
1 Shot-Wait 10-20 Sec.
1 Shot 15-30 Sec.
1 Shot Wait 10-20 Sec.
1-2 Shots-Wait 20-30 Sec.
1-2 Shots-Wait 20-30 Sec.
1 Shot Wait 10-20 Sec.
1-2 Shots Wait 25-45 Sec.
1-2 Shots-Wait 20-30 Sec.

### EGGS

Hard Boiled.....	
Soft Boiled.....	
Poached.....	
Scrambled (12).....	

10-20 minutes
4 minutes
3-4 Shots-3 minutes
8-10 minutes

### PASTA (pre-cooked refrigerated)

Macaroni and Cheese casserole .....	
Rice.....	
Spaghetti.....	

3 Shots 90-120 Sec.
2 Shots 45-60 Sec.
2 Shots 45-90 Sec.

### SEAFOOD

Clams and Oysters.....	
Crab, King (1 lb.).....	
Lobster Tail (8 oz.) 4 pcs.....	
Lobster Tail, frozen (8 oz.) 4 pcs.....	
Lobster, whole.....	
Orange Roughy Fillet.....	
Shrimp, fresh (1 lb.).....	
Shrimp, frozen (1 lb.).....	
Scallops, large.....	

7 minutes
4-5 minutes
13 minutes
10 minutes
6-8 minutes
6-7 minutes
5-7 minutes
6-8 minutes
6-8 minutes

### MEATS

Bacon (pre-cooked).....	
Bratwurst (pre-cooked).....	
Chicken (1/2 lb. pre-cooked).....	
Deli Meats.....	
Hamburger (pre-cooked).....	
Hot Dogs, 10 per lb. (1 lb.).....	
Ribs (pre-cooked).....	
Sausage links (pre-cooked).....	
Tamales.....	
Tamales, frozen.....	

45 Sec.
5 minutes
3-4 minutes
45-60 Sec.
1-2 minutes
3 minutes
2-4 minutes
1-2 minutes
4 minutes
6-7 minutes

### VEGETABLES

Artichoke.....	
Asparagus.....	
Broccoli, whole (1-2 lbs.).....	
Brussel Sprouts.....	
Carrots, sliced.....	
Cauliflower, whole (1-2 lbs.).....	
Corn on the cob.....	
Fluerets, various.....	
Green Beans (1 lb.).....	
Potatoes, whole (small).....	
Potatoes, mashed (2 quarts).....	

25-30 minutes
8-10 minutes
10-12 minutes
12-15 minutes
7-8 minutes
12-15 minutes
5 minutes
5 minutes
12-15 minutes
20 minutes
6 minutes

## Warranty Midco® International Inc Limited Warranty Policy Exclusions Terms, Customer Requirements and Instructions

**All claims should be filed through Warranty Central.  
Call factory for information (773 604 8700)**

Only Authorized Service Providers are authorized to provide Limited Warranty service on all EmberGlo®, a Division of Midco® International Inc., food equipment as described under and Midco® International Limited Warranty Policy. A list of providers can be found on our web site: [www.emberglo.com](http://www.emberglo.com)

### **Provisions:**

In lieu of an implied warranty, all repairs and replacement parts furnished under our Limited Warranty shall be f.o.b. point of distribution, but the owner must pay the necessary freight, delivery and labor costs involved when required. Any Federal, State or Local taxes are also extra. This Limited Warranty is effective for a period of one year from date of installation. EmberGlo® Char Broilers and EmberGlo® Electric Food Preparation Equipment manufactured by Midco International, sold under the EmberGlo® trademark, are guaranteed to be free from defect in material and workmanship under normal use and service for a period of 1 (one) year after the date of original installation. Midco's obligation under this Limited Warranty Policy shall be limited to repairing or replacing, at our option, any part of said equipment which Midco examination shall disclose to its satisfaction to be thus defective.

### **Exclusions:**

This Limited Warranty Policy does not apply to damages resulting from accident, misuse, abuse or alteration, nor does it apply to limer steam generators, nor does it apply to any consequential damages. Most geographical areas require the use of distilled or demineralized water. Tap water is permissible only with ES Series Steamers. Nor does it apply to Barbrig's®, briquettes, or rods used in gas broilers. Midco's obligation will be the replacement of the product or parts removed.

### **Terms:**

Under the terms of this Limited Warranty Policy, models considered portable (devices with cords and plug caps such as EmberGlo Steamers) must be taken or returned to the nearest service provider, transportation prepaid, returned transportation collect. Non-portable units with permanent wiring will be serviced on the customer's premises. Under these terms, Midco agrees, within the terms of this Limited Warranty period, to make all repairs at no charge by the authorized service provider. Labor and mileage charges submitted by any other provider not authorized will be the responsibility of the customer.

### **Customer Requirements:**

All charges related to repairs made one (1) year after the date of original installation, during the Limited Warranty period will be the responsibility of the customer. The product registration information is located on the product I.D. plate.

If a part is defective due to workmanship or materials and is removed from the product within the applicable warranty period and returned to Midco in accordance with the following procedure described, Midco will, at its option, either repair or replace the part.

**Call the factory for instructions on returned goods.**

**No equipment may be returned without written authorization from MIDCO. Returned goods must be shipped prepaid to the factory.**

**⚠ WARNING: Improper installation and use of this product could result in personal or property injury.**